

RoHS Compliant Product
A suffix of "-C" specifies halogen free

DESCRIPTION

The STP117Sxx series of positive adjustable and fixed regulators are designed to provide 1A with high efficiency. All internal circuitry is designed to operate down to 1.4V input to output differential.

On-chip trimming adjusts the reference voltage to 1%. Current limit the typical value of 1.5A allows to minimizing the stress on both the regulator and the power source circuitry under overload conditions.

FEATURES

- Adjustable or Fixed Output 1.2V, 1.8V, 2.5V, 3.3V
- Output Current of 1A
- Low Dropout, 1.2 V typ. at 1A Output Current
- 0.04% Line Regulation
- 0.2 % Load Regulation
- 100% Thermal Limit Burn-In
- Fast Transient Response

APPLICATIONS

- High Efficiency Linear Regulators
- Post Regulators for Switching Supplies
- Adjustable Power Supply

MARKING

Part Number	Marking
STP117SA	1117SA
STP117S12	1117S12
STP117S18	1117S18
STP117S25	1117S25
STP117S33	1117S33

xx:Vout	
A: ADJ	25: 2.5V
12: 1.2V	33: 3.3V
18: 1.8V	

The last letter(s) of Part No. denote the Output Voltage

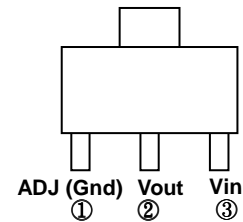
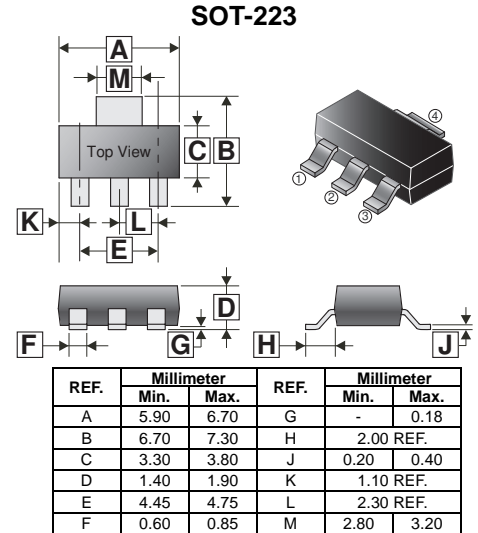

PACKAGE INFORMATION

Package	MPQ	Leader Size
SOT-223	4K	13 inch

TYPICAL APPLICATION CIRCUIT

Fixed Voltage Regulator

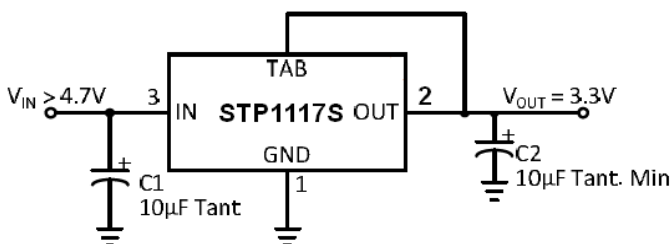

Notes:

- 1) C1 needed if device is far from filter capacitors.
- 2) C2 minimum value required for stability.

Adjustable Voltage Regulator

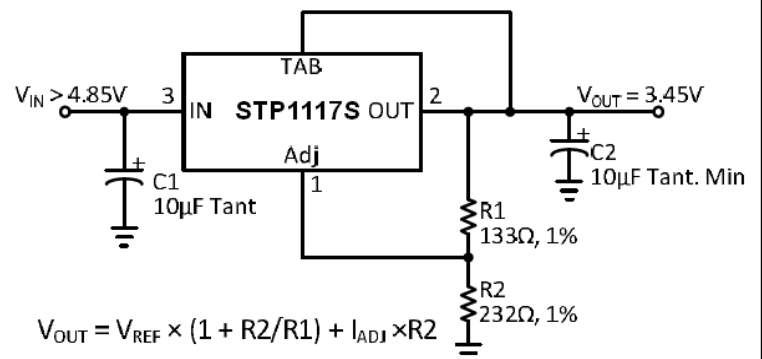

ABOSLUITE MAXIMUM RATINGS

Parameter	Symbol	Value	Unit
Input Voltage	V_I	20	V
Minimum ESD Rating (HBM)	V_{ESD}	3	kV
Lead Temperature (Soldering, 10sec.)	T_L	300	°C
Thermal Resistance Ambient Ambient	$R_{\theta JC}$	15	°C/W
Operating Junction Temperature Range	T_J	-40~+125	°C
Storage Temperature Range	T_{stg}	-65~+150	°C

Note:

Stresses above those listed in "Absolute Maximum Ratings" may cause permanent damage to the device. This is a stress only rating and operation of the device at these or any other conditions above those indicated in the operational sections of this specification is not implied.

FUNCTIONAL BLOCK DIAGRAM

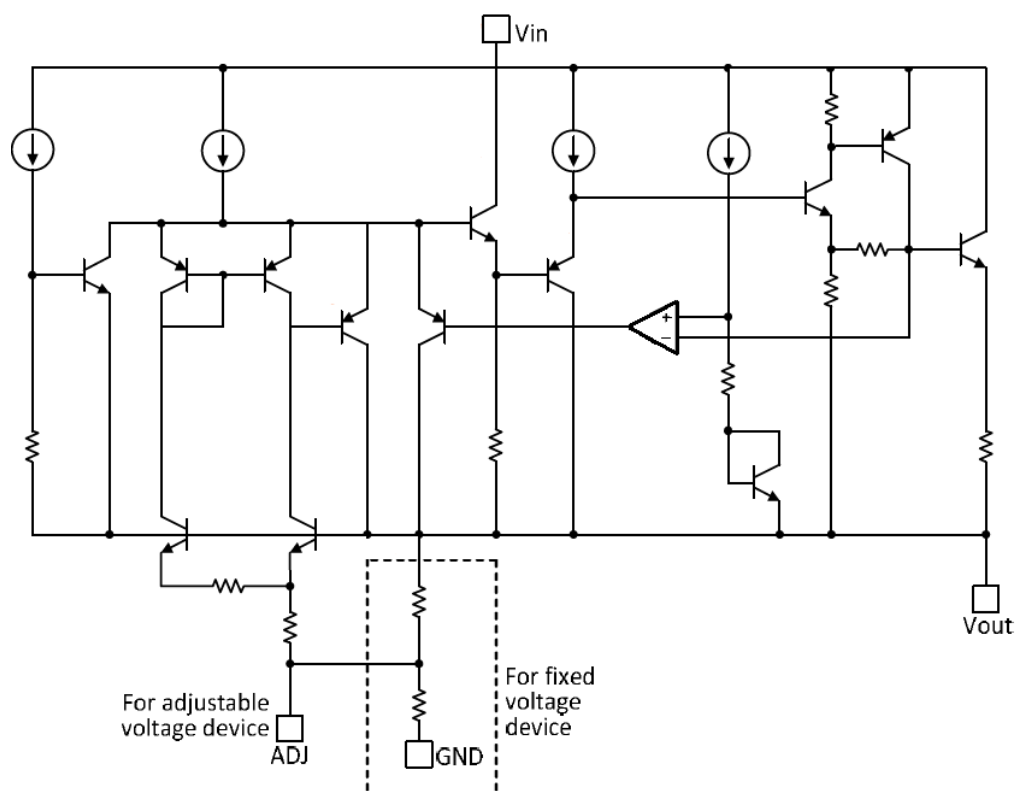

ELECTRICAL CHARACTERISTICS ($I_{LOAD}=0mA$, $T_J=25^{\circ}C$ unless otherwise specified)

Parameter	Symbol	Device	Min.	Typ.	Max	Unit	Test conditions
Operating Voltage ⁴	V_{IN}		-	-	16	V	
Reference Voltage ¹	V_{IROC}	Adj	1.232	1.250	1.268	V	$I_{LOAD}=10mA$, $V_{IN}=5V$
			1.225	1.250	1.275		$I_{LOAD}=10mA$ to 1A, $1.5V \leq V_{IN}-V_{OUT} \leq 10V$ ⁴
Output Voltage ¹	V_O	All fixed version	-1.5	-	1.5	%	$V_{IN}=V_{OUT}=1.5V$, Variator from nominal V_{OUT}
			-2	-	2		$1.5V \leq V_{IN}-V_{OUT} \leq 10V$, $I_{LOAD}=0mA$ to 1A, Variator from nominal V_{OUT} ⁴
		$V_{OUT}=1.2V$	-3	-	2		
Output Voltage Accuracy @Wafer Testing	V_O	All	-0.6	0	0.6	%	$V_{IN}=V_{OUT}=1.5V$, $I_{LOAD}=10mA$
Line Regulation	LNR	All	-	0.04	0.238	%	$I_{LOAD}=10mA$, $1.5V \leq V_{IN}-V_{OUT} \leq 10V$ ⁴
Load Regulation ¹	LDR	All	-	0.2	0.25	%	$V_{IN}=V_{OUT}=1.5V$, $I_{LOAD}=10mA$ to 1A ⁴
Minimum Load Current	I_L	adj	-	2	7	mA	$V_{IN}=5V$, $V_{ADJ}=0V$ ⁴
Ground Pin Current		All fixed version	-	35	10	mA	$V_{IN}=V_{OUT}=1.5V$, $I_{LOAD}=10mA$ to 1A ⁴
Adjust Pin Current		Adj	-	35	60	uA	$I_{LOAD}=10mA$, $1.5V \leq V_{IN}-V_{OUT} \leq 10V$ ⁴
Current Limit		All	1	1.5	2	A	$V_{IN}-V_{OUT}=1.5V$ ⁴
Ripple Rejection ²	RR	All	60	-	-	dB	$V_{IN}-V_{OUT}=2.5V$, $I_{LOAD}=1A$
Dropout Voltage ^{1,3}	V_D	All	-	1.2	1.4	V	$I_{LOAD}=1A$ ⁴
Temperature Coefficient		All	-	-	0.015	%/ $^{\circ}C$	$V_{IN}-V_{OUT}=1.5V$, $I_{LOAD}=10mA$ ⁴

Notes:

1. Low duty pulse testing with Kelvin connections required.
2. 120Hz input ripple (C_{ADJ} for ADJ = 25 μ F).
3. ΔV_{OUT} , $\Delta V_{REF}=1\%$
4. The specifications which apply over the full temperature range: $-40^{\circ}C \leq T_J \leq 125^{\circ}C$.

TYPICAL CHARACTERISTICS

Load Transient Response

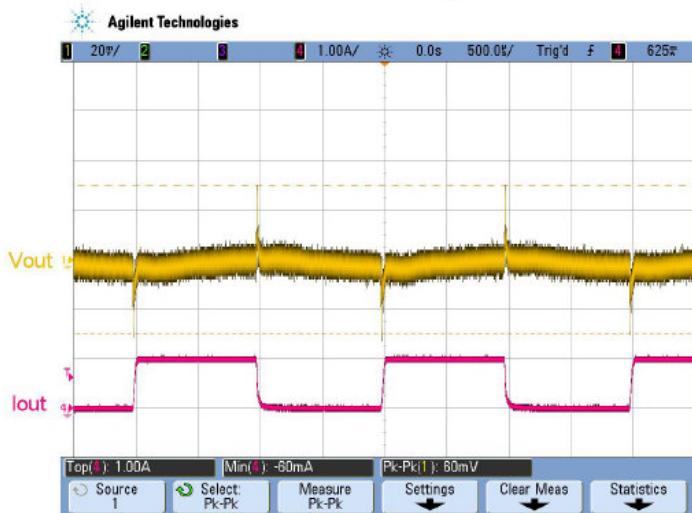

Line Transient Response

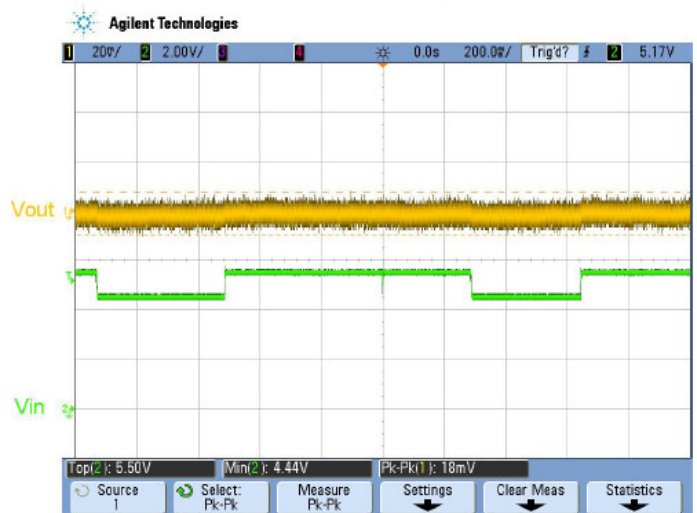

Load Regulation (Input Voltage = 5V)

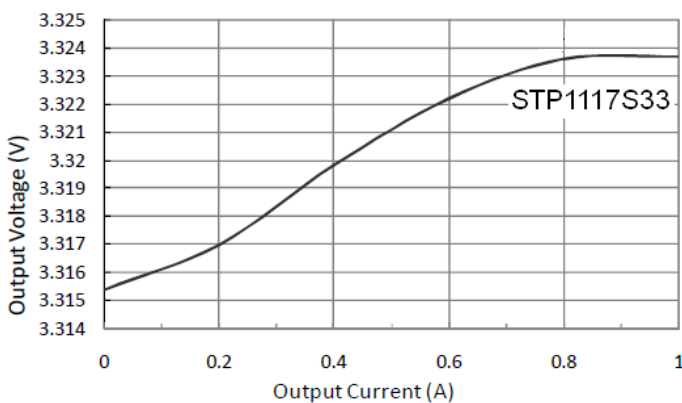

Line Regulation (Output Current = 100mA)

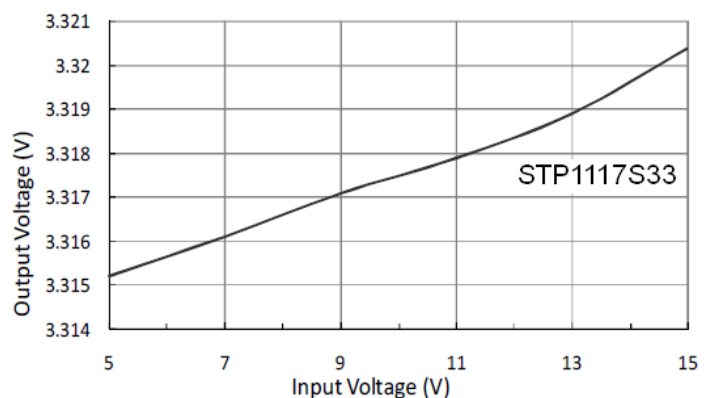

Output Voltage vs. Input Voltage

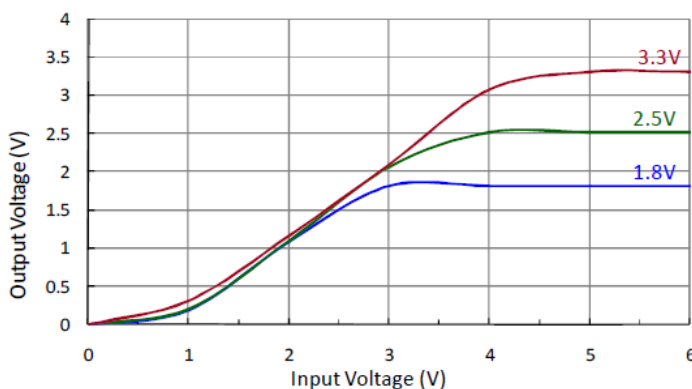

Input Current vs. Input Voltage

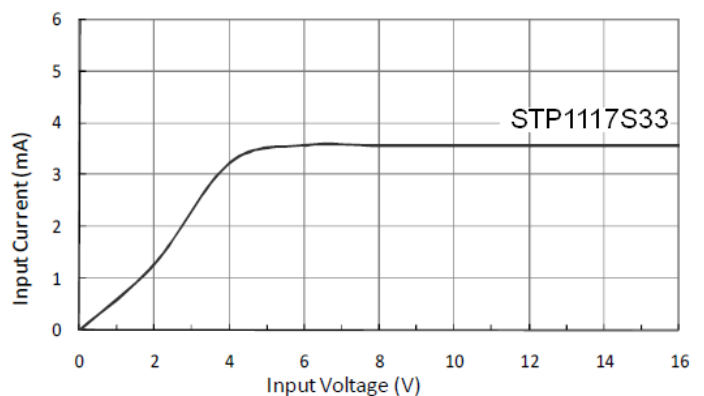

TYPICAL CHARACTERISTICS

Current Limit vs. Input Voltage

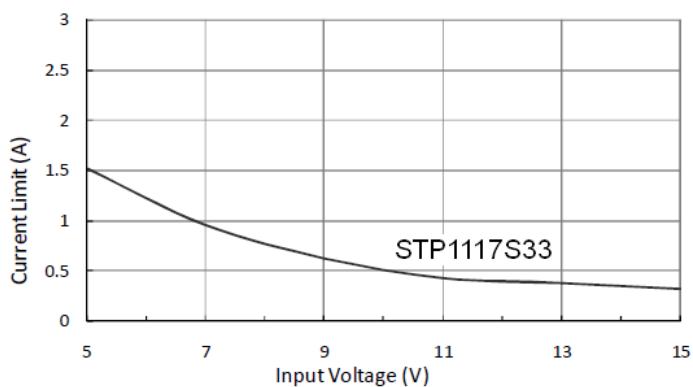

Output Voltage vs. Temperature (3.3V)

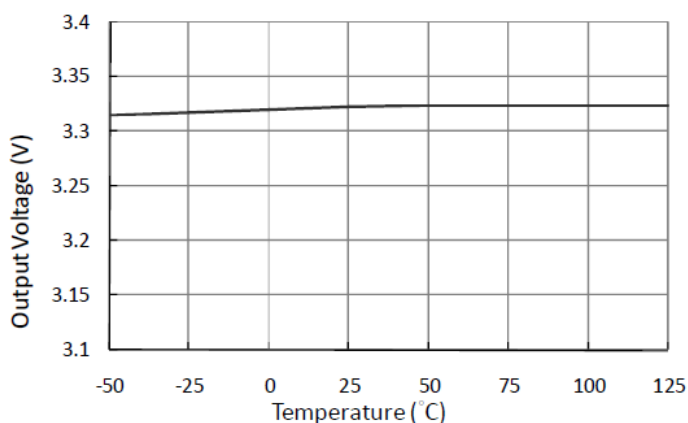

Output Voltage vs. Temperature (2.5V)

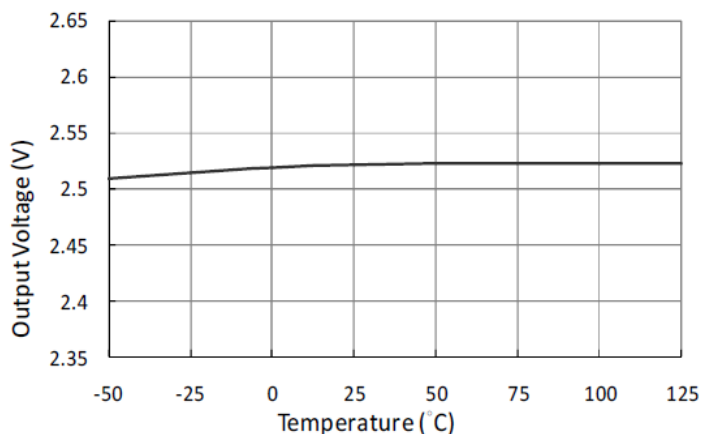

Output Voltage vs. Temperature (1.8V)

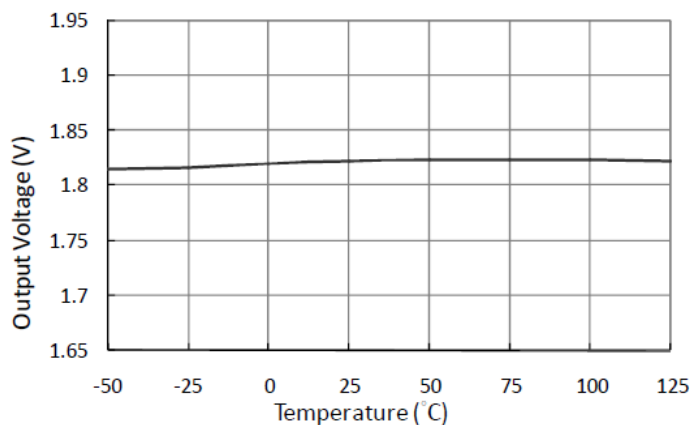

PSRR vs. Frequency

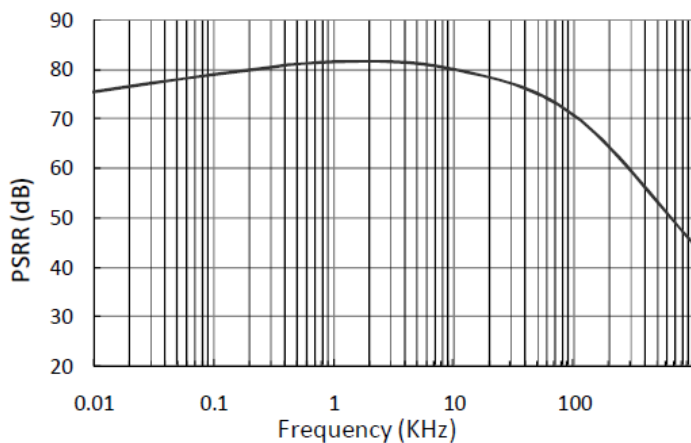

APPLICATION INFORMATION

Output Voltage

The STP117S develops a 1.25V reference Voltage Between the output and the adjust terminal. By placing A resistor between these two terminals, a constant current Is cause to flow through R1 and down through R2 to set the Overall output voltage. Normally, this current is chosen to be the specified minimum load current of 10mA . For fixed voltage devices R1 and R2 are included in the device.

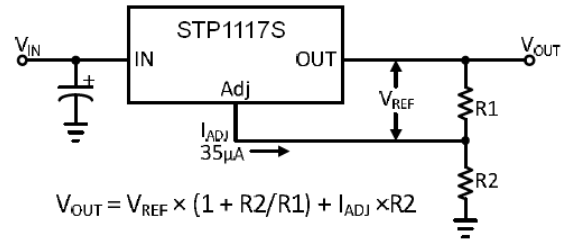

$$V_{OUT} = V_{REF} \times (1 + R2/R1) + I_{ADJ} \times R2$$

Figure 1: Basic adjustable regulator.

Load Regulation

When the adjustable regulator is used, load regulation will be limited by the resistance of the wire connecting the regulator to the load. The data sheet specification for load regulation is measured at the output pin of the device.

Best load regulation is obtained when the top of the resistor divider (R1) is tied directly to the output pin of the device not to the load. For fixed voltage, devices the top of R1 is internally connected to the output, and the ground pin can be connected to low side of the load. If R1 is connected to the load, R_P is multiplied by the divider ratio, the effective resistance between the regulator and the load would be:

$$R_P \times (1 + R2/R1), R_P = \text{Parasitic Line Resistance}$$

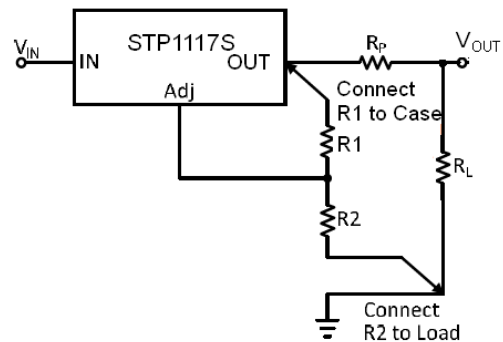

Figure 2: Connections for best load regulation.

Input Capacitor

An input capacitor of 10µF or greater is recommended. Tantalum or aluminum electrolytic capacitors can be used for bypassing. Larger Values will improve ripple rejection by bypassing the input to the regulator.

Output Capacitor

The STP117S requires an output capacitor to maintain stability and improve transient response. Proper capacitor selection is important to ensure proper operation. The STP117S output capacitor selection is dependent upon the ESR (equivalent series resistance) of the output capacitor to maintain stability. When the output capacitor is 10µF or greater, the output capacitor should have an ESR less than 1Ω. This will improve transient response as well as promote stability. A low-ESR solid tantalum capacitor works extremely well and provides good transient response and stability over temperature. Aluminum electrolytics can also be used, as long as the ESR of the capacitor is <1Ω. The value of the output capacitor can be increased without limit. Higher capacitance values help to improve transient response and ripple rejection and reduce output noise.

Ripple Rejection

The curves for Ripple Rejection were generated using an adjustable device with the adjust pin bypassed. With a 25µF bypassing capacitor, 75dB ripple rejection is obtainable at any output level. The impedance of the adjust pin capacitor, at the ripple frequency, should be <R1. R1 is normally in the range of 100Ω to 200Ω. The size of the required adjust pin capacitor is the function of the input ripple frequency. At 120Hz, with R1=100Ω, the adjust pin capacitor should be 13µF. For fixed voltage devices and adjustable devices without an adjust pin capacitor, the output ripple will increase as the ratio of the output voltage to the reference voltage (V_{OUT} / V_{REF}).